

C2E-133.41CS

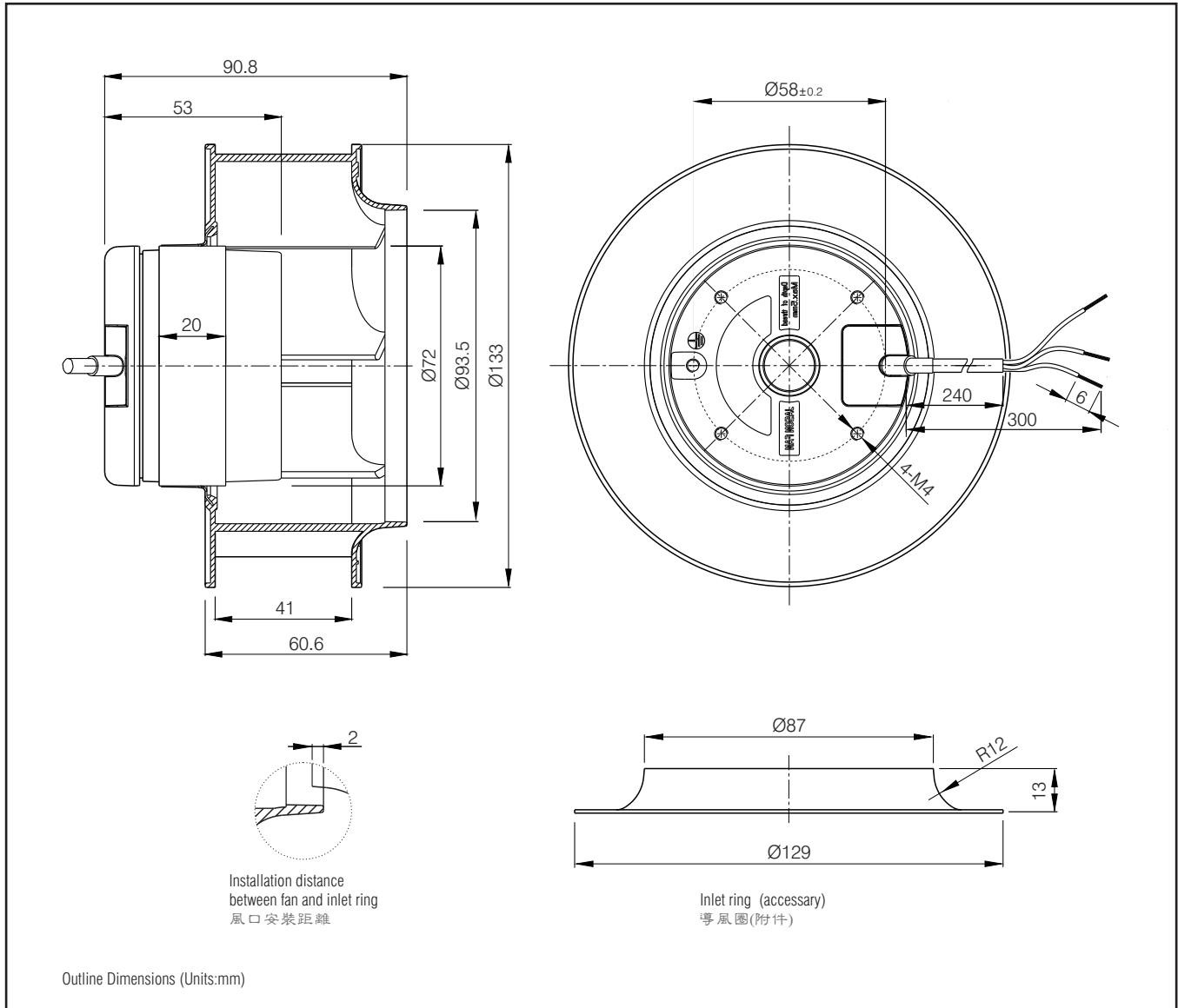

- Ⓐ Rotation direction of blades : CW seen from the front impellers
- Ⓑ Power Connection: UL3266-18 Lead wire
- Ⓒ Unit weight: 660g

- Ⓐ 風扇旋向: 從扇葉方向看為順時針
- Ⓑ 電源連接: UL3266-18 引線連接
- Ⓒ 單機重量: 660g

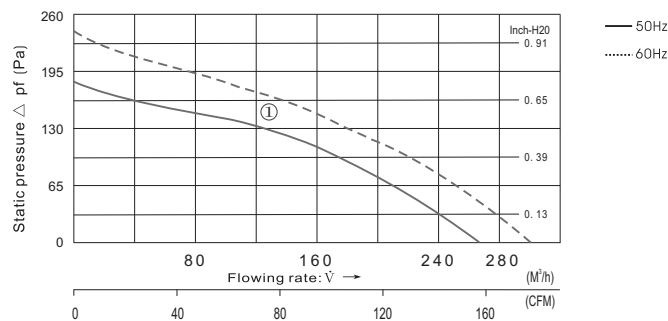

Parameters

Type 產品型號	Motor 電機	Rated Voltage 額定電壓 V	Frequency 周波數 Hz	current 電流 (A)	Power 功率 (W) ^{+10% -20%}	Speed 回轉速度 (min ⁻¹)	Max Air Flow 最大風量 CFM m³/h	Static Pressure 最大靜壓 (Pa)	Noise 噪音 (dB)	Curve 曲綫	Capacitor 電容 (μF)
C2S-133.41CS	M2S7201-AB	115	50	0.51	38	2650	159 270	180	52	①	-----
			60	0.42	35	2700	177 300	240	55		
C2E-133.41CS	M2E7201-AB	230	50	0.25	41	2550	159 270	180	52	①	-----
			60	0.23	40	2670	177 300	240	55		