

# Cage External Rotor Motor Fan

籠形外轉子電機風扇

# 220mm

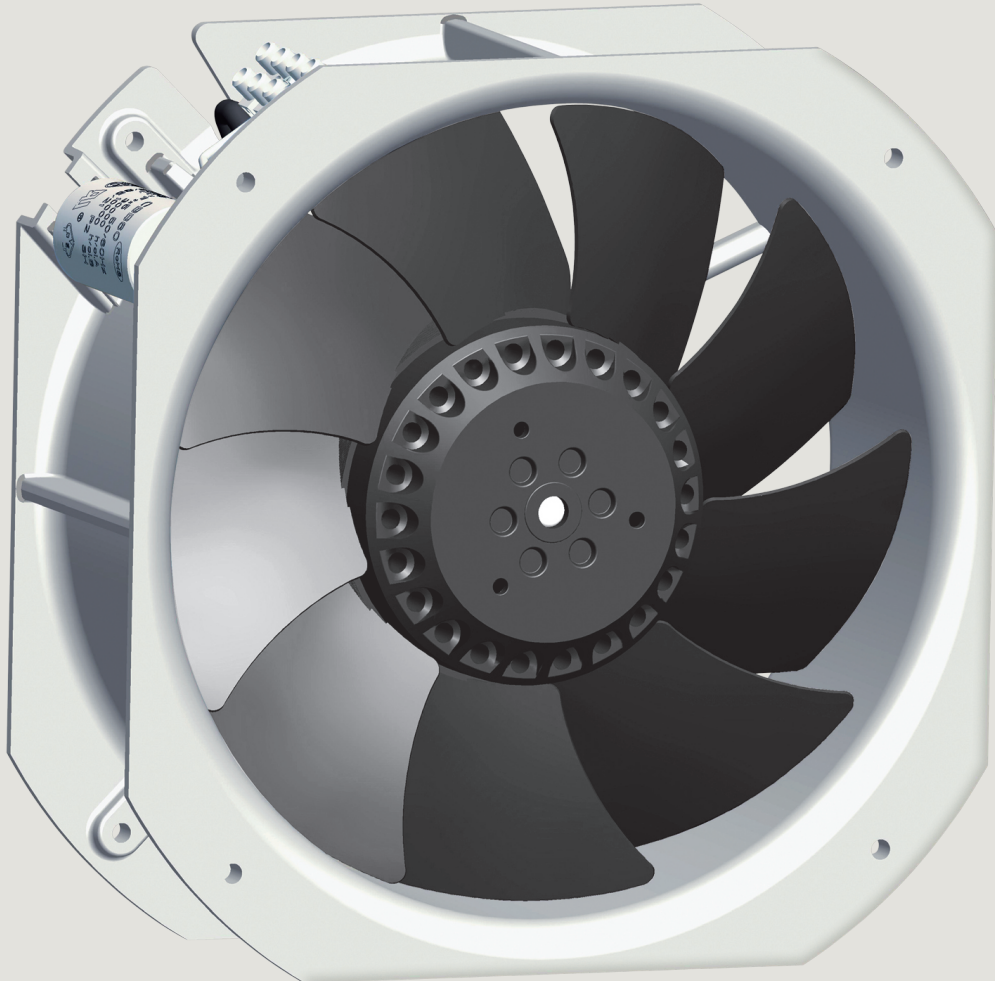

## 1 Frame

Aluminum die-casting, surface is finished by anti-corrosion treatment with primary color or black electrophoresis anti-corrosion treatment

## 2 Impeller

Metal impellers are welded to motor rotor, and surface is finished by black electrophoresis anti-corrosion treatment

## 3 Operation Temperature/Humidity

Temperature -30°C ~ +80°C Humidity 0% ~ 95%

## 4 Protection

Motor Internal with automatic recovery thermal protector

## 5 Withstand Voltage

AC 1,800V, 1 min at 0.5mA, 50/60 Hz

## 6 Insulation System

design according to IEC61858 Grade F,

## 7 Protection Grade IP44

## 1 機架:

鋁合金壓鑄，表面原色抗腐蝕處理或黑色電泳防腐蝕處理

## 2 風葉:

金屬葉片焊接在外轉子上，表面黑色電泳防腐蝕處理

## 3 運行溫/濕度範圍:

溫度 -30°C ~ +80°C 濕度 0% ~ 95% (非凝結狀態)

## 4 保護:

電機內部帶自動恢復熱保護器

## 5 絕緣耐壓:

AC 1800V 0.5mA 50/60Hz下耐受1分鐘

## 6 絕緣系統:

按 IEC61858 F級設計

## 7 電機防護等級:

IP 44

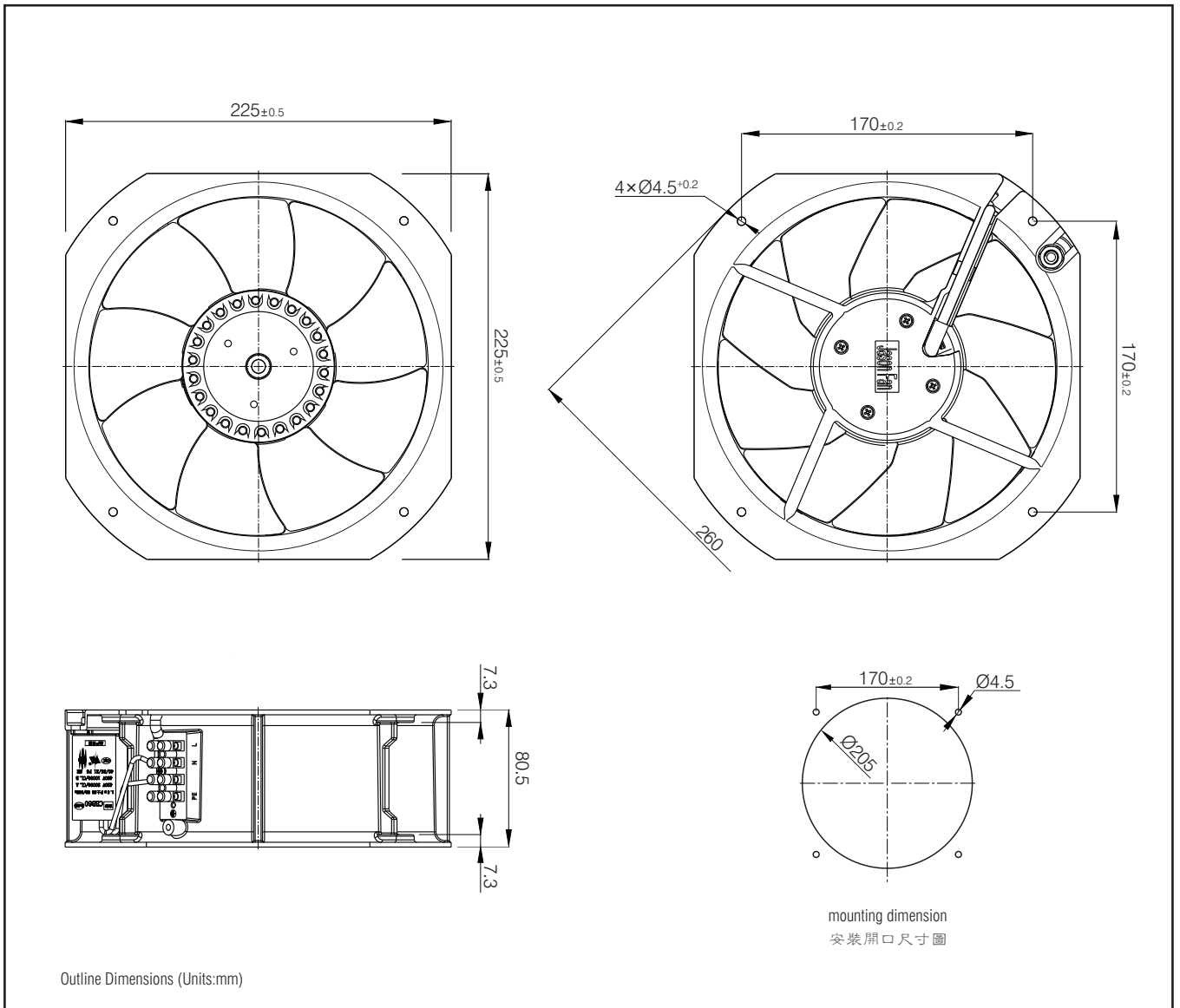

- Ⓐ Rotation direction of blades : CCW seen from the front impellers
- Ⓑ Power Connection: PA-10 terminal connection
- Ⓒ Unit weight: 2.2kg

- Ⓐ 風扇旋向：從扇葉方向看為逆時針
- Ⓑ 電源連接：PA-10 端子連接
- Ⓒ 單機重量：2.2kg

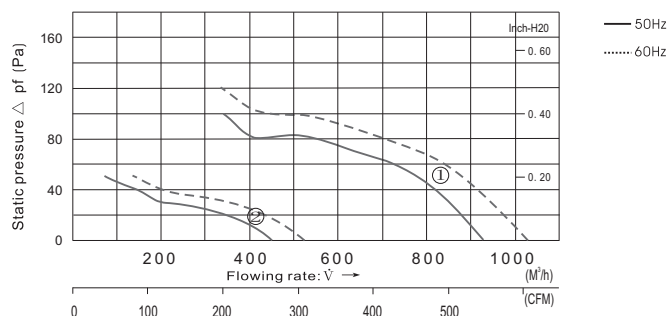

## Parameters

Type 產品型號	Motor 電機	Rated Voltage 額定電壓 V	Frequency 周波數 Hz	current 電流 (A)	Power 功率 (W) <small>+10% -20%</small>	Speed 回轉速度 (min <sup>-1</sup> )	Max Air Flow 最大風量 CFM    m <sup>3</sup> /h	Static Pressure 最大靜壓 (Pa)	Noise 噪音 (dB)	Curve 曲綫	Capacitor 電容 (μF)
FJ22081MAB	M2S9201-AF	115	50	0.60	65	2550	546    925	100	59	①	5.0/250
			60	0.64	75	2750	596    1010	120	61		
FJ22082MAB	M2E9201-AF	230	50	0.30	65	2550	546    925	100	59	①	1.5/450
			60	0.34	77	2750	596    1010	120	61		
FJ22083MAB	M2D9201-AF	380	50	0.18	64	2550	546    925	100	59	①	0.5/630
			60	0.20	78	2750	596    1010	120	61		
FJ22082MAB-4E	M4E9201-AF	230	50	0.13	27	1350	254    430	50	40	②	0.68/450
			60	0.12	27	1600	313    530	50	44		