

Centrifugal Fan

離心風機

Ø315



- 1 Motor**
Cage type capacitor structure external rotor motor
- 2 Impeller**
Impact molding of aluminium alloy plate
- 3 Allowable environment temperature and humidity range:(under unconcretionary condition)**
-40°C ~ +70°C (temperature) 0% ~ 95% (humidity)
- 4 Protection**
Motor Internal with automatic recovery thermal protector
- 5 Withstand Voltage**
AC 1,800V ,1 min at 0.5mA, 50/60 Hz
- 6 Insulation Grade**
design according to IEC61858 Grade F,
- 7 Protection Grade**
IP44

- 1 電機:**
籠形電容式外轉子電機
- 2 葉輪:**
鋁合金板沖壓成型,
- 3 允許環境溫度和濕度範圍:(非凝結狀態)**
-40°C ~ +70°C (溫度) 0% ~ 95% (濕度)
- 4 保護:**
電機內部帶自動恢復熱保護器
- 5 絕緣耐壓:**
AC 1800V 0.5mA 50/60Hz下耐受1分鐘
- 6 絕緣隔絕等級:**
按 IEC61858 F級設計
- 7 電機防護等級:**
IP 44

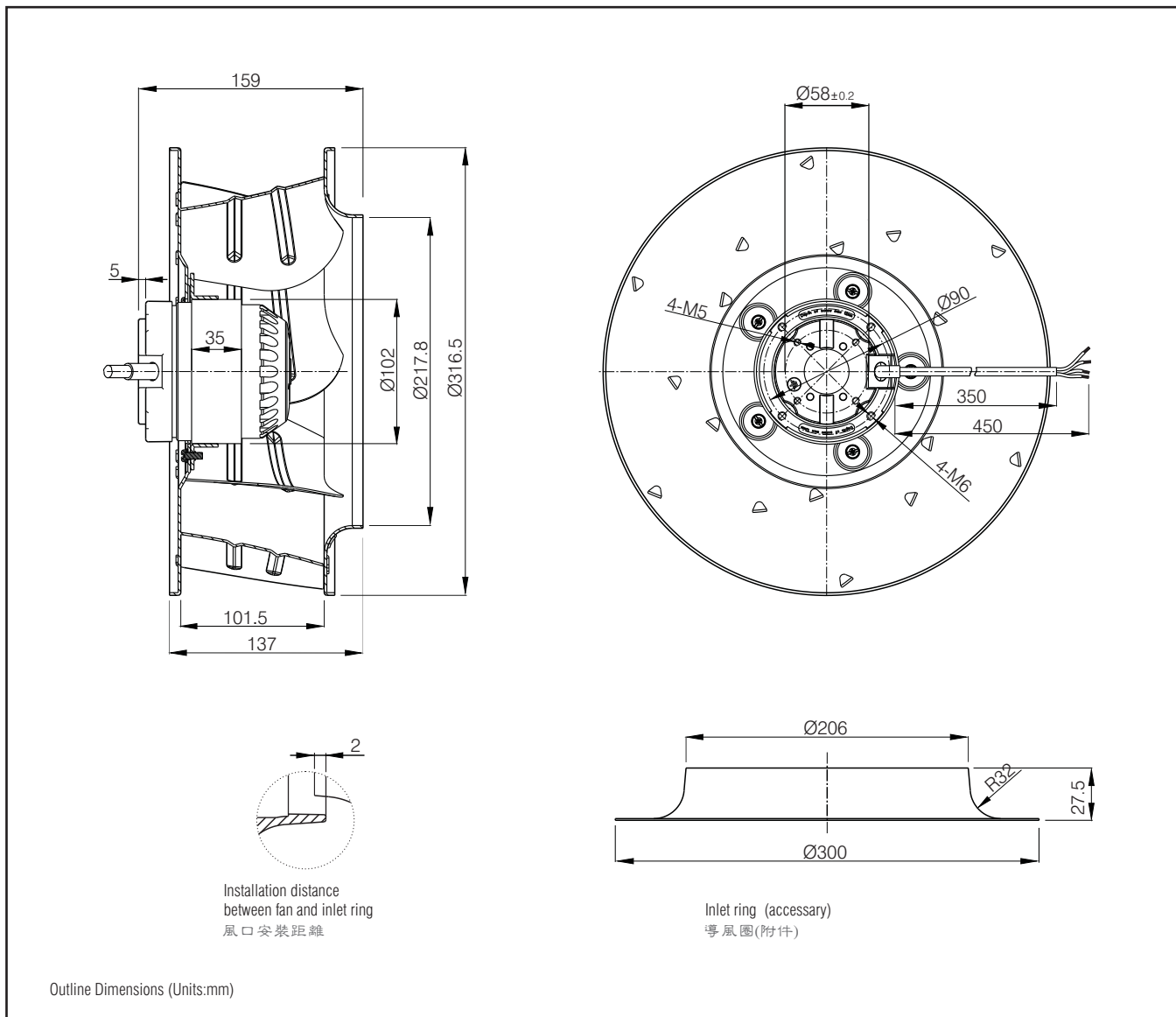

- Ⓐ Rotation direction of blades : CW seen from the front impellers
- Ⓑ Power Connection: UL3266-18 Lead wire
- Ⓒ Unit weight: 3.8kg

- Ⓐ 風扇旋向: 從扇葉方向看為順時針
- Ⓑ 電源連接: UL3266-18 引線連接
- Ⓒ 單機重量: 3.8kg

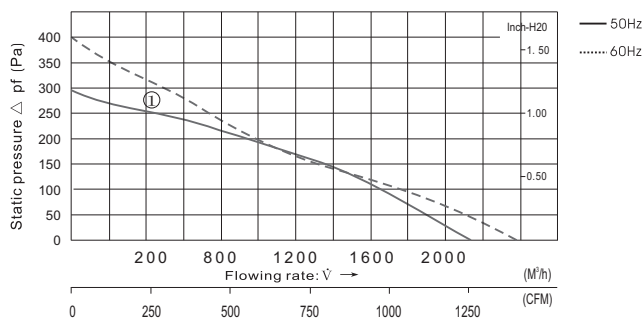

Parameters

Type 產品型號	Motor 電機	Rated Voltage 額定電壓 V	Frequency 周波數 Hz	current 電流 (A)	Power 功率 (W) <small>+10% -20%</small>	Speed 回轉速度 (min ⁻¹)	Max Air Flow 最大風量 CFM m ³ /h	Static Pressure 最大靜壓 (Pa)	Noise 噪音 (dB)	Curve 曲綫	Capacitor 電容 (μF)
C4E-315.101	M4E10201-AF	230	50	0.51	115	1380	1256 2130	290	59	①	4.0/450
			60	0.70	160	1500	1404 2380	400	62		
C4D-315.101	M4D10201-AF	380	50	0.40	128	1380	1256 2130	290	59	①	1.0/630
			60	0.47	170	1540	1404 2380	400	62		
C4ED-315.101	M4ED10201-AF	230/400	50	.62/.35	137/135	1360	1256 2130	290	59	①	-----
			60	.58/.32	167/170	1500	1404 2380	400	62		